

# MUD HOG CRUSHER RANGE

## For wet or sticky materials

The well proven BJD range of Mud Hogs, which includes single direction and reversible units, is specially designed for reducing wet and sticky materials which, in conventional type crushers, would build up on the interior surfaces and choke the machine.

The simple, but highly effective principle employed in the Mud Hog is an independently driven and constantly moving adjustable breaker plate which ensures that built up material is carried into the path of the hammers and cleared so preventing and bridging of the feed opening. Since the bottom of the machine remains partially open, material is freely discharged.



### BENEFITS

- Model range suitable for permanent, mobile, demountable and container systems
- Single direction and reversible units
- Capacities up to 2000 TPH depending on duty
- Flexible machine easily adjustable to give varying product sizes
- Processes sticky materials with high moisture content (clays to 40% mortar)
- Crushes and blends in one operation
- High fines production from shales and stones
- Mineral liners produced for landfill sites without need to add Bentonite



*BJD Processing  
Mud Hog Module*

### SPECIFICATION SUMMARY

- Eight standard model sizes
- Constantly moving adjustable breaker plate keeps machine clean
- Variable rotor speed
- Open base





# MUD HOG SPECIFICATIONS

\* Drive jackshaft arrangement may be necessary on larger motors.

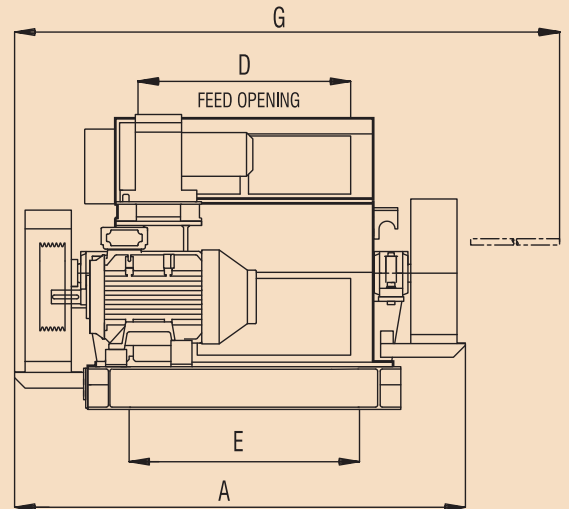
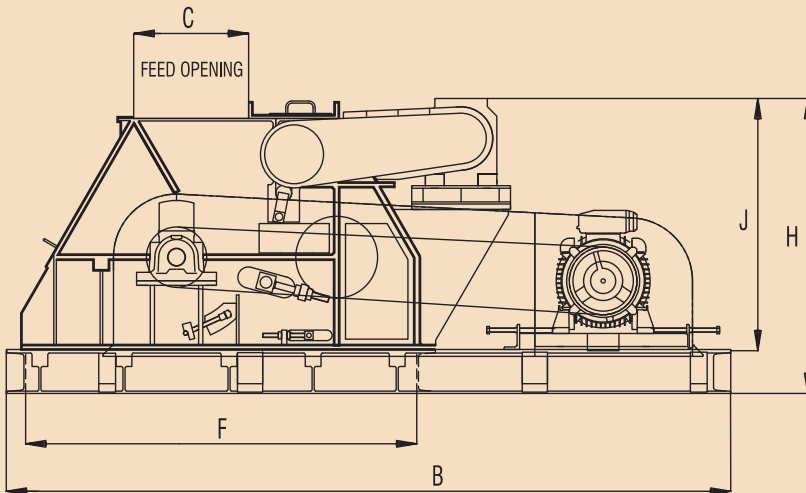

MODEL	A	B	C	D	E	F	G	H	J	APPROX. WEIGHT MACHINE ONLY (Kg)
2012	1300	3000	406	330	406	1422	1555	1237	1137	1682
2420	1840	3500	518	580	664	1861	2600	1400	1200	3000
2436	2240	3500	518	979	1066	1861	3000	1400	1200	3700
3636	2570	4780	794	1052	1182	2492	3000	2170	1919	11995
4236	2775	6000	1067	940	1054	4300	3000	2500	2200	19500
4272	3775	6000	1067	1940	2054	4300	4630	2500	2200	23180
5466	4300	7000	1200	1700	1830	4300	5000	2662	2362	27500
5484	4700	7000	1200	2160	2290	4300	5400	2662	2362	30500

Standard Mud Hog range – other sizes available on request.

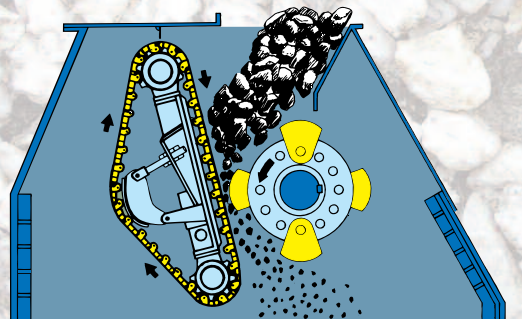

## TYPICAL APPLICATIONS

The Mud Hog is capable of processing materials such as:

- Clays – For geological barriers and mineral liners for landfill
- Fireclays
- Ores
- Coal
- Shale
- Chalk
- Limestone
- Contaminated earth mixed with bacteria substrate

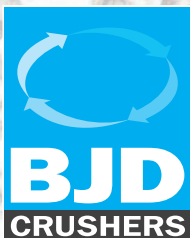

**BJD Crushers Ltd.**

Tel: +44 (0)1226 241 425

Email: [sales@bjdcrushers.co.uk](mailto:sales@bjdcrushers.co.uk)

[www.bjdcrushers.co.uk](http://www.bjdcrushers.co.uk)



*Capacities, dimensions and weights will vary with the characteristics of each individual material. The details contained within this leaflet are for information purposes only and we reserve the right to change product specifications without prior notice.*